

TECHNICAL PAPER

OpticalCon[®]

Fiber Optic Connection System



Authors:

Neutrik AG
Im alten Riet 143
9494 Schaan
Liechtenstein

Projekt: OpticalCon[®]
Version: 3
Pages: 29



NEUTRIK[®]
CONNECTING THE WORLD

Subject:

Mechanical, electrical and optical tests applied to the OpticalCon® transmission system for Pro Audio / Video industry purposes with main focus on changes in attenuation.

Optical performance is being examined with regard to attenuation and its variation vs. environmental and mechanical conditions.

This documentation describes the results of the test series conducted at Neutrik AG, University of Applied Sciences of Technology Buchs NTB and Electrosuisse-Fehraltorf (SEV Association for Electrical Engineering, Power and Information Technologies).

The tests were carried out in accordance with the IEC-Standard main groups IEC 60794 and IEC 61300 as well as to Neutrik internal specifications.

Content of Test Reports

- 1 Optical Attenuation.....4
- 2 Vibration.....6
- 3 Cable Retention9
- 4 Locking mechanism 10
- 5 Impact..... 11
- 6 Mating Durability 13
- 7 Change of Temperature..... 15
- 8 Flexing 17
- 9 Dust20
- 10 Sealing Gasket23
- 11 Cable Drum.....24
- 12 Contact Resistance.....25
- 13 Dielectric Strength.....26
- 14 Insulation Resistance.....27
- 15 Current Capacity28
- Attachment: Cable specifications.....29

1 Optical Attenuation

Object:

Examination of the receptacle NO2-4FD in combination with the OpticalCon® cable connector to determine the attenuation in a fiber optic system. For the test of the cable connector a completely assembled OpticalCon cable was used. See [fig. 1](#).

Test Set-Up:

Test specimens:

Single mode: NKO2SA-0-2 (2 m length)
Multi mode: NKO2M-0-1 (1 m length)

Test procedure according to IEC 61300-3-4 figure 4 with mode filter described in table 3 for multi mode, for single mode no mode filter was used.

Test equipment: light source EXFO FLS-600
power meter EXFO FPM-600

Launching cables: 0.9 mm precision fibres

Reference complex: precision adapter FLC-FLC

Measuring wave lengths: Single mode 1,310 nm
Multi mode 850 nm

Cable length: Single mode 2 m
Multi mode 1 m

Comment: Short cable lengths do not affect attenuation remarkably and are therefore not considered.

1 Optical Attenuation (contd.)

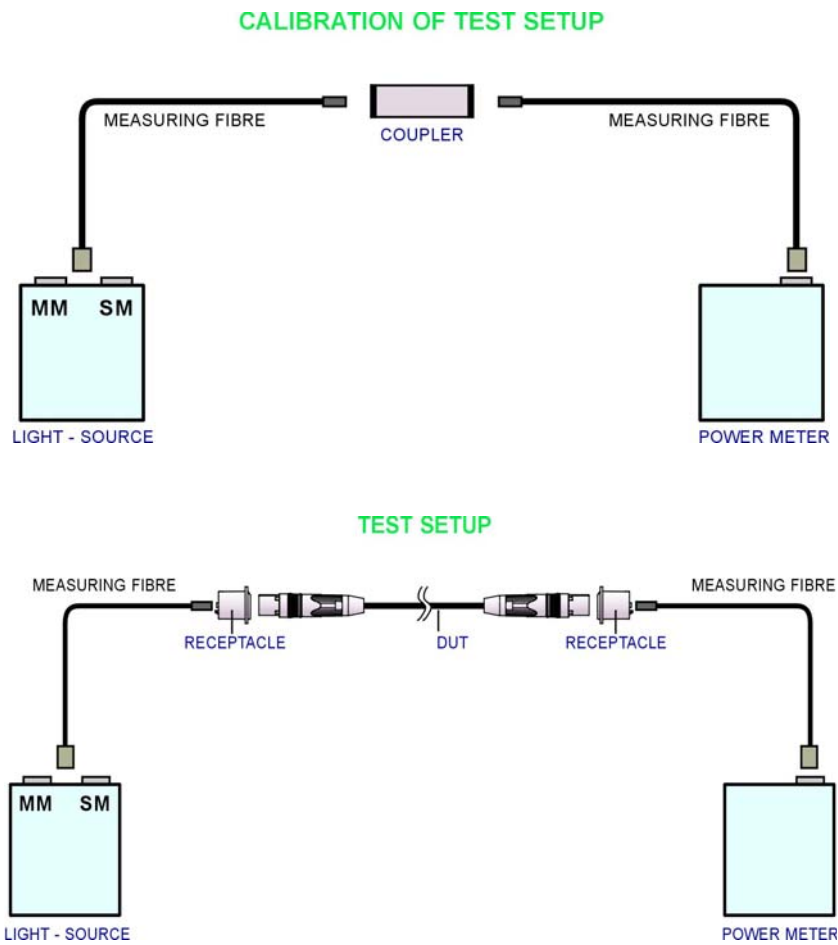


Fig. 1: Simplified measuring arrangement

Limit Values (per mating pair):

Single mode: 0.5 dB
Multi mode: 0.35 dB

Results:

Basis of test series: 50 sets of cable assemblies

Single mode: 0.10 – 0.44 dB
Multi mode: 0.08 – 0.32 dB

2 Vibration

Object:

Examination of the two components, receptacle NO2-4FD and the OpticalCon[®] cable connector. The intention of the test was to determine their attenuation in a fiber optic system before, during and after the vibration test.

In addition the test presents the change in contact resistance of the electrical contacts as well as the function of the mechanical locking system and the wear.

The test was carried out by an independent laboratory: NTB, "Interstaatliche Hochschule für Technik Buchs" division "Labor Mess- und Simulationstechnik" located in Buchs/ Switzerland.

Test Set-Up:

For the vibration test two receptacles NO2-4FD per axis were mounted. The front side was mated with a NKO2M-4S75-0-1 OpticalCon cable. The rear end was connected with the test instrument via precision measuring cables (see [fig. 2a/b](#)).

The applied test set-up complies with IEC 61300-2-1 table 1.

Shaker:	TIRAVIB Model 5200, controlled by an external power amplifier and a PC with software VibeLab-Pro (fig. 2 a/b).	
Test instruments:	light source	EXFO FLS-600
	power meter	EXFO FPM-600
Launching cables:	0.9 mm precision fibres, assembled by H&S	
Measuring wave lengths:	single mode	1,310 nm
	multi mode	850 nm
DUT cable length:	single mode	2 m
	multi mode	1 m
Comment:	Short cable lengths do not affect attenuation remarkably and are therefore not considered.	

2 Vibration (contd.)

Vibration Severity:

Frequency range:	10 – 55 Hz sinusoidal
Amplitude displacement:	1.52 mm (3.04 mm p-p)
Acceleration:	up to 20 g (200 m/s ²)
Sweep rate:	2 min/cycle
Number of sweeps:	15
Axis:	X, Y, Z

After 15 cycles the receptacles were changed to the next axis without disconnecting the pugs to avoid any mismatching.

Results:

Attenuation before, during and after vibration test:

Changes in attenuation:

Single mode: - 0.08 dB to - 0.03 dB
Multi mode: - 0.03 dB to + 0.13 dB

The reason for the attenuation improvement compared to the initial values may result from new positioned ferrules as a result of vibration.

Measurement during vibrations showed no variation in attenuation.

Electrical Contact Resistance

The contact resistance has changed from 4.6 mΩ average to 4.7 mΩ per contact.

Mechanical

The locking mechanism withstands this extreme vibration without any problems, i. e. no separation or functional deterioration occurred.

2 Vibration (contd.)



Fig. 2a: Vibration equipment and test cable arrangement

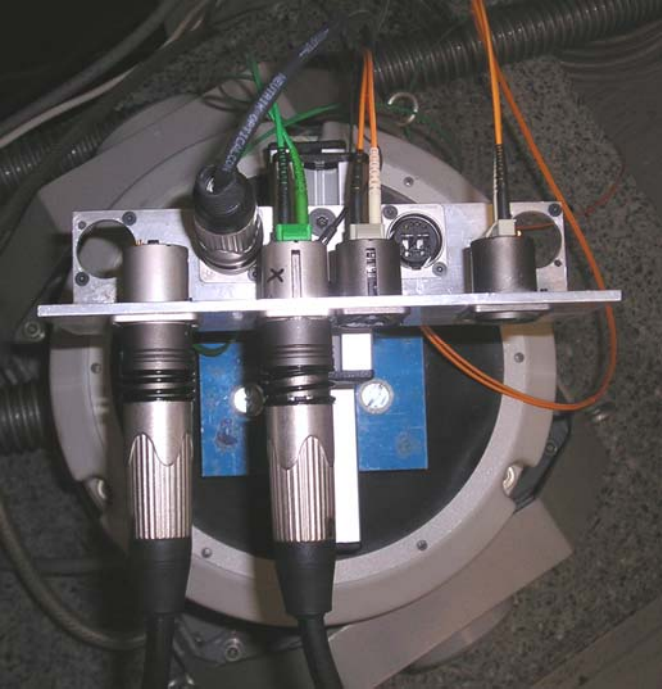


Fig. 2b: Vibration equipment and test cable arrangement

3 Cable Retention

Object:

Test of the cable retention efficiency. The OpticalCon cables NKO* were exposed to tractive forces until the cable started to move.

Test Set-Up:

The applied test procedure is referred to IEC 61300-2-4.

Tension-Tester: Versa Test Mecmesin 0-1,000N
([fig. 3](#))

Measuring Instruments: AFG-R 1000N Mecmesin

Assembled cable types: NKO2M-0-1 multi mode 2 fibers
NKO2M-4S75-0-1 multi mode 2 fibers and 4 copper wires
NKO2SA-0-1 single mode 2 fibers
NKO2SA-S1-0-1 (SMPTE) single mode 2 fibers
and 4 copper wires

Results:

NKO2M-0-1 multi mode 2 fibers	> 500N
NKO2M-4S75-0-1 multi mode 2 fibers and 4 copper wires	> 500N
NKO2SA-0-1 single mode 2 fibers	> 500N
NKO2SA-S1-0-1 (SMPTE) single mode 2 fibers and 4 copper wires	> 350N



Fig. 3: Equipment for examination of cable retention

4 Locking Mechanism

Object:

Tensile strength measurement of the locking mechanism.

Test Set-Up:

Same test set-up as used in clause 3. Cable Retention. Instead of the cable a mechanical adapter was used to fix the plug.

Results:

Tensile strength > 1,000N

At a force of 1,000N the test was stopped without any damages of the locking device.

5 Impact

Object:

The impact test is performed to show possible deformations or plug malfunction of the internal mechanism due to heavy mechanical exposure.

Test Set-Up:

The applied test procedure is referred to the IEC 61300-2-12 Method A pendulum drop (fig. 4).

Test item:	OpticalCon® cable connector
First part of test:	front side of connector protected by a protection cap of EPDM (protection cap is supplied with each cable drum)
Second part of test:	no connector protection

Parameters of Test:

Distance from centre of rotation:	2.25 m
Number of drops:	5
Height of falling:	1.0 – 1.9 m
Ground:	steel plate, thickness 25 mm
Plug fixation:	small wire

Results:

Tests 1 – 3	no visible abrasions, no functional problems
Test 4	minimal abrasions at the edge of the plug, but no functional problems

5 Impact (contd.)



Fig. 4: Test set-up "Impact"

Test #	with cap	drop height m	drops	comment	result
1	yes	1.0	5		no visible abrasion full function
2	yes	1.9	5		no visible abrasion full function
3	yes	1.0	5	extremely manual acceleration	no visible abrasion full function
4	no	1.5	5	valuation after each drop	minimum abrasion full function

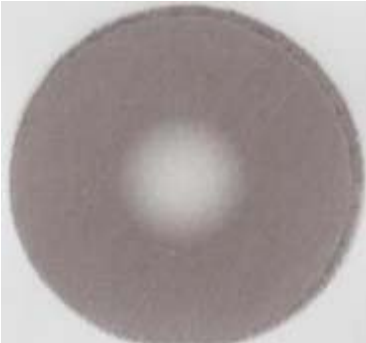
Table 1: Impact test IEC 61300-2-12 method A

6 Mating Durability (contd.)

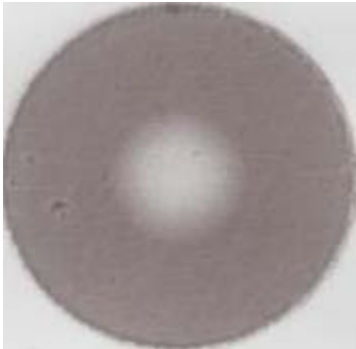


Fig. 5: Test facility for mating durability

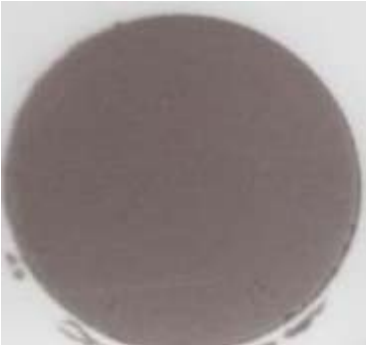
Microscopic inspection:



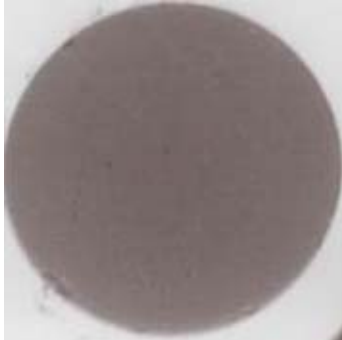
Channel 1 multi mode:
no visible degradation



Channel 2 multi mode:
harmless degradation



Channel 1 single mode:
no visible degradation



Channel 2 single mode:
harmless degradation

7 Change of Temperature

Object:

Variations in attenuation due to temperature changes.

The test was arranged with a single mode cable drum which is more critical than multi mode.

Test Set-Up:

Test procedure according to IEC 61300-2-22 in combination with IEC 61300-3-4 figure 4.

The test was realized in a temperature testing chamber type WEISS WK11-180/40.

Test cycles: 16 (96h)

Profile of temperature: -25°C to +75°C (fig. 6)

Test instruments: light source EXFO FLS-600
power meter EXFO FPM-600

Launching cables: 0.9 mm precision fibers, constantly connected with the DUT (device under test) through a hole in the test chamber.

Measuring wave lengths: single mode at 1,310 nm

Cable length: 300 m

Test specimen: NKO2SA-3-300

Results:

Maximum increase in attenuation 0.42 dB over the whole temperature range.

7 Change of Temperature (contd.)

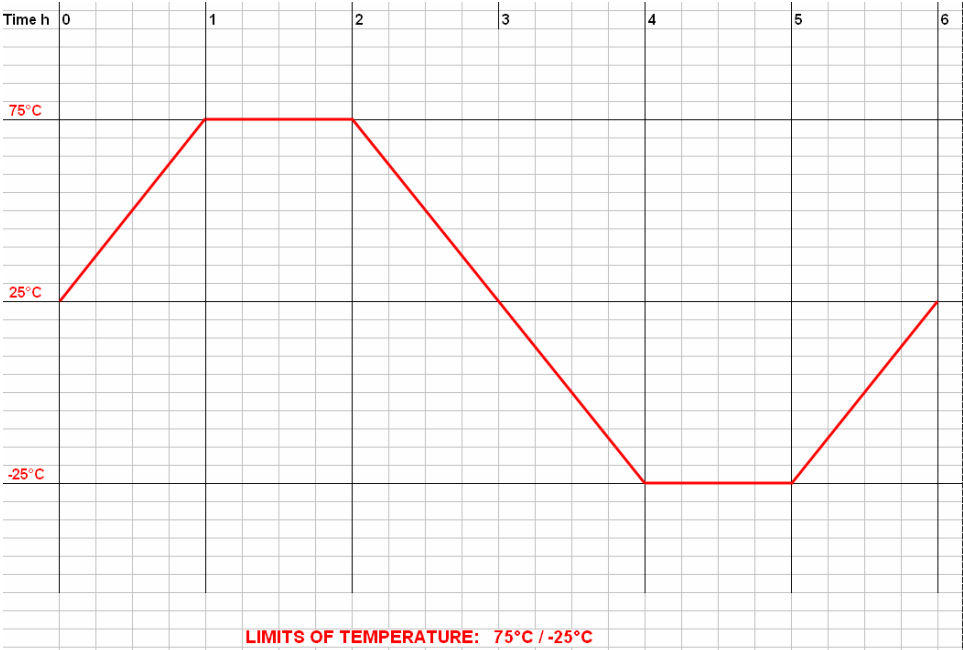


Fig. 6: Profile of temperature

8 Flexing

Object:

Variations of attenuation and mechanical damage of fiber optic cable due to a defined flexing procedure.

Assembled cable types: NKO2M-0-1 Multi mode 2 fibres
NKO2SA-0-1 Single mode 2 fibres
NKO2SA-S1-0-1 (SMPTE) Single mode 2 fibres and
4 copper wires

Test Set-Up:

Measurement of attenuation before, during and after flexing cycles.

Test procedure according to IEC 61300-2-44 in combination with IEC 61300-3-4 figure 4 with mode filter as defined in table 3 for multi mode, no mode filter for single mode.

Test equipment:	<u>fig. 7 and 8</u>	
Test cycles:	1,000 / 5,000	
Mass of weight:	10 N or 20 N depending on cable type	
Flexing angle:	$\pm 90^\circ$	
Flexing speed:	ca. 12 cycles/min	
Test Instruments:	light source	EXFO FLS-600
	power meter	EXFO FPM-600
Launching cables:	0.9 mm precision fibers, assembled by H&S	
Measuring wave lengths:	single mode	1,310 nm
	multi mode	850 nm
DUT cable length:	single mode	1 m
	multi mode	1 m

8 Flexing (contd.)

Results:

a) Change in attenuation:

Single mode	0.05 dB to 0.20 dB
Multi mode	0.00 dB to 0.03 dB

b) Mechanical cable damage:

1,000 cycles:	no damage
5,000 cycles:	no significant damage, single strands (AWG 16) of SMPTE cable partly broken

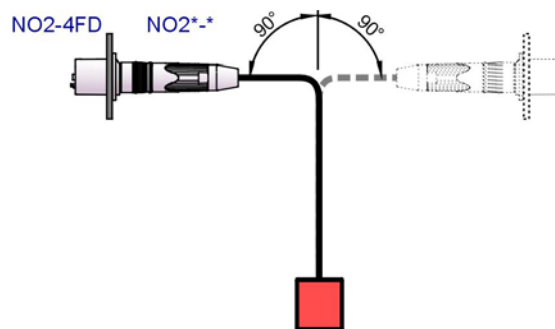


Fig. 7: Principle of Test according to IEC 61300-2-44 (IEC 61300-3-4)

8 Flexing (contd.)

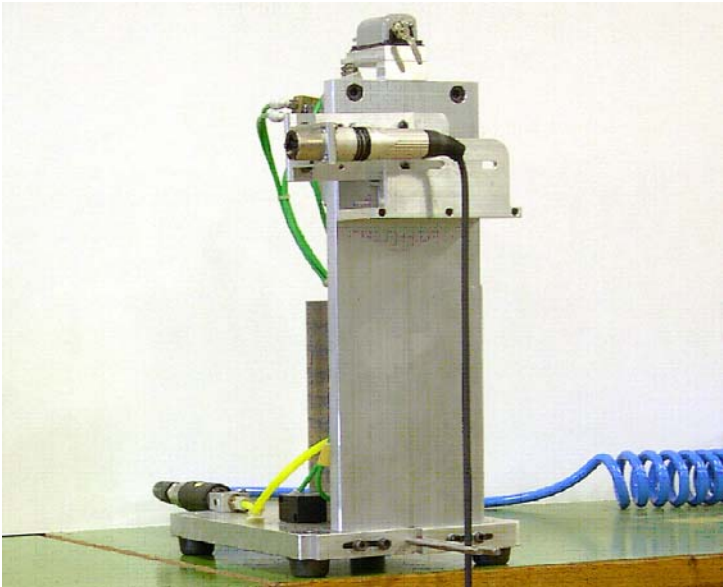


Fig. 8: Test Equipment and Fixture for flexing test

9 Dust

Object:

Variations of attenuation due to massive dust penetration. The test was carried out with single mode cables where soiling of the connecting surface effects much more attenuation than at multi mode cables.

The test was carried out by an independent laboratory: Electrosuisse, test laboratory PQ/PIK in 8320 Fehraltorf, Switzerland.

Test Set-Up:

The OpticalCon connector was exposed to dust from both sides in wired condition for 60 minutes. The built-in sealing shutters protected the optical conductor at the front side, the plugged-in LC-Duplex connectors shielded the rear side.

Test procedure according to IEC 61300-2-27 in combination with IEC 61753-1-1 Tab. A5 Test No.16 and IEC 61300-3-4 figure 4.

Test specimen: NO2-4FD - Receptacle

Particle size: $d < 150 \mu\text{m}$

Dust type: talcum powder

Temperature: 19°C

Relative humidity: 54%

Duration of penetration: 1 h

Test Instruments: light source EXFO FLS-600
power meter EXFO FPM-600

Launching cables: 0.9 mm precision fibers

Measuring wave lengths: single mode 1,310 nm

DUT cable length: single mode 2 m

9 Dust (contd.)

Results:

	Attenuation	Initial	After Contamination
NO2-4FD-R	A	0.31	0.34
	B	0.36	0.38
NO2-4FD	A	0.38	0.39
	B	0.33	0.36

Table 2: Dust test - attenuation in dB

Channel A was defined as for the front side of the receptacle

The corresponding power level was calibrated at 4.91 dBm @ 1310nm (=0.00dB)

Maximum increase in attenuation: 0.03 dB

The IP rating can be defined with IP 5x.



Fig. 9: Dust sediment on the rear side of the receptacle after 60 min.

9 Dust (contd.)



Fig. 10: Dust sediment on the front side of the receptacle after 60 min.

10 Sealing Gasket

Object:

Durability test of the sealing cover surface. Long-term load of the closed sealing cover by a constant laser beam.

The intention is to find out if the silicon layer alters or a deposition is formed on the fiber surface of the connector.

Test Set-Up:

An interconnection was inserted into a chassis connector type NO2-4FD from the rear. The fiber surface of the interconnection had direct contact to the cover surface. The second end of the interconnection was connected to a light source.

See fig. 4

Light source:	EXFO	FLS-600
Power meter:	EXFO	FPM-600
Test parameter:	Wavelength:	1310nm
	Output power:	4.6dBm (referenced 0dB)
	Duration:	12h

Result:

No difference between referencing and measuring after the duration of test: $\pm 0\text{dB}$.

The surfaces of the fiber and the gasket as well showed no mechanical variation in the area of the fiber contact (checked by microscope).

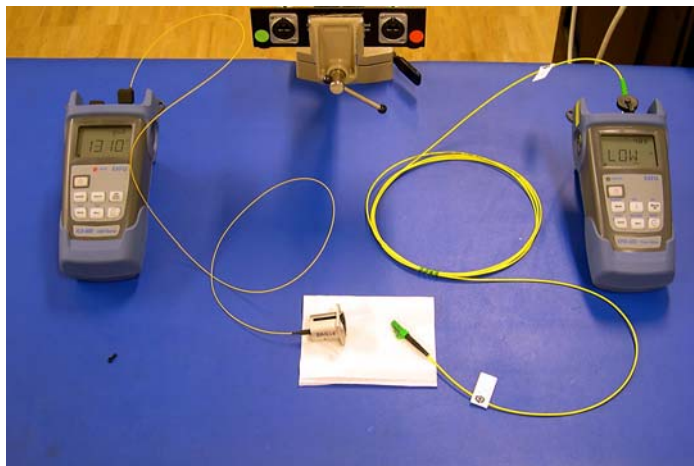


Fig. 4: Test Set-Up

11 Cable Drum

Object:

Variations of attenuation due to winding quality on cable drums.

First part of the test: attenuation measurement of perfectly wounded drum

Second part of test: attenuation measurement of unwinded cable

Third part of the test: spooling of the cable drum in a typical on stage manner, i. e. with a lot of crossed cable windings; attenuation measurement

Test Set-Up:

Test procedure according to chapter 1 Attenuation.

Parameters:

Drum assembly: NKO2SA-3-1000 - single mode 2 x 9/125 μ m

Cable length: 1,000 m

Wave length: 1,310 nm

Results:

First test (spooled cable drum): attenuation initial channel A: 0.34 dB
channel B: 0.37 dB

Second test (unwinded cable drum): change in attenuation - 0.04 dB to - 0.07dB

Third test (spooled cable drum): increase of initial attenuation + 0.01 dB
to + 0.08 dB

12 Contact Resistance

Object:

Initial value and variation of contact resistance.

OpticalCon[®] cable connector mated with the receptacle NO2-4FD before and after 1,000 mating cycles.

Test Set-Up:

Test procedure according to IEC 60512-2 test 2a

Measuring Instrument: HIOKI – 3540 Millivoltmeter

Results:

Contact Resistance [mΩ]		
	measured average value	conditional value
initial	4.6	6.0
after 1,000 cycles	5.7	7.0

13 Dielectric Strength

Object:

Same test set-up as used in clause 11 Contact Resistance. It was checked in completely mated, half mated and unmated condition. Each combination of contact to contact and contact to shell was judged.

Test Set-Up:

Test procedure according to IEC 60512-2 test 4a

Measuring Instrument: GOR-1 Dielectrometre

Test Parameter: 0 – 6 kV

The conditional value of dielectric strength was defined with > 1.5 kV.

Results:

Minimum dielectric strength: 2.0 kV

14 Insulation Resistance

Object:

Same test set-up as used in clause 11 Contact Resistance.

Test Set-Up:

Test procedure according to IEC 60512-2 Test 3a

Measuring Instrument: METRISO C
maximum measurable isolation resistance 100 GΩ

Test Parameter: test voltage 500V DC

The insulation resistance was defined with $> 10\text{G}\Omega$.

Results:

Minimum insulation resistance: 64.7GΩ

15 Current Capacity

Object:

Temperature rise of contacts as a result of electrical current.

Test Set-Up:

Test procedure according to IEC 60512-5-1 test 5a

Current source: VAREG, 3V 0-50 A rms

Measuring Instrument: TESTO 935 Thermometer, 2 channels
-50 - +350°C

The maximum temperature rise was defined generally with < 40K.

The measurements were realized for the following wires and currents:

- 1 contacts 1-4 wired with 0.22 mm², 6 Amps through all contacts
- 2 contacts 1+4 wired with 1.5 mm², 10 Amps through both contacts in case of SMPTE application
- 3 contacts 1+4 wired with 1.5 mm², 10 Amps through both contacts and additionally contacts 2+3 wired with 0.22 mm², 1 Amp through both contacts in case of SMPTE application.

Results:

Ad 1: 26.7K

Ad 2: 23.1K

Ad 3: 28.6K

A rated current of 6 A (10 A for the SMPTE cable) can be defined.

Attachment: Cable specifications

	2M-4S75	2M	2S (SA) *	2S (SA)-S1 *
number of fibers	2	2	2	2
fiber type	multi mode	multi mode	single mode	single mode
Attenuation	2.5 dB/km @ 850 nm 0.7 dB/km @ 1,300 nm	3 dB/km @ 850 nm 1 dB/km @ 1,300 nm	0.5 dB @ 1,300 nm (1,550 nm)	0.5 dB @ 1,300 nm (1,550 nm)
core diameter	50 µm	50 µm	9 µm	9 µm
cladding diameter	125 µm	125 µm	125 µm	125 µm
fibre cable design	tight-buffer	tight-buffer	tight-buffer	tight-buffer
copper wires	4 x AWG 18 (0.75 mm ²)	-	-	2 x AWG 24 2 x AWG 16
outer shield	-	-	-	copperbraided-tinned, 95 % coverage
strength member	2 mm GFK	-	-	1.02 mm stainless steel
cable retention	Aramid yarn	Aramid yarn	Aramid yarn	crimp type
overall diameter	8.9 mm	5 mm	5 mm	9.2 mm
jacket material	PUR	PUR	PUR	PVC Belflex®
Color	black, matte	black, matte	black, matte	black, matte
min. bending radius	10 cm	4 cm	4 cm	10 cm
Weight	78 kg/km	23 kg/km	23 kg/km	118 kg/km
operating temp.	-20°C to +70°C	-55°C to +85°C	-55°C to +85°C	-30°C to +60°C
crush resistance	200 N/cm IEC 60794-1-2 E3	440 N/cm TIA/EIA-455-41 mil. requ.	440 N/cm TIA/EIA-455-41 mil. Requ.	1,800 N FOTP-41
impact resistance	o.r.	200 impacts EIA/TIA-455-25 mil. requ.	200 impacts EIA/TIA-455-25 mil. requ.	20 cycles @1.32 lbs FOTP-25
flex resistance	5,000 cycles IEC 60794-1-2 E6	2,000 cycles TIA/EIA-455-104 mil. requ.	2,000 cycles TIA/EIA-455-104 mil. requ.	1,000 cycles @ 3.6" FOTP-104 15,000 cycles @
tensile strength	1750 N	600 N	600 N	o.r.
applicable standards	-	-	-	SMPTE311M

* S = PC connector surface
SA = APC connector surface